

MAXIMUM UPLIFT CAPACITY (LBS)			
Web Gage	#10 sds	1/4" Steel	3/8" Steel
035	3	970	970
	4	1290	1290
	5	1615	1615
046	4	2230	2230
	5	2400	2400
057	4	2400	2400

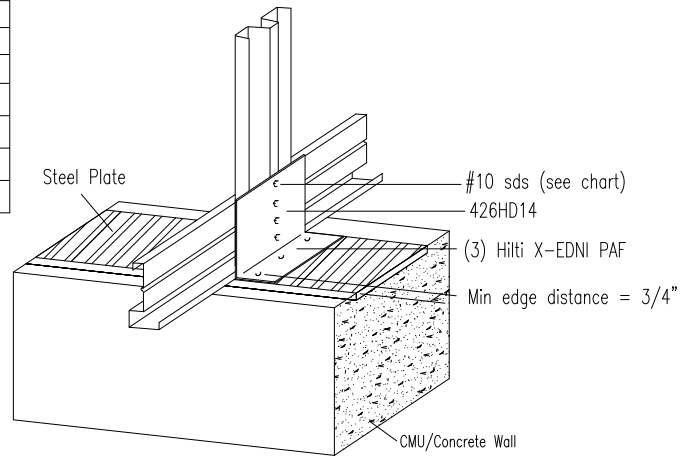

- 1) Web or heel stiffener attached with the greater of 4 - #10 sds or the quantity shown.
- 2) Minimum screw spacing = 9/16"
- 3) Uplift values include 1.33 increase for wind or seismic. No further increase is permitted. For uplifts not resulting from wind or seismic, reduce capacities to 75% of values shown.
- 4) See Fastener Manufacturer's catalog for installation requirements and application limits.
- 5) PAF fasteners to be placed thru pre-drilled holes.
- 6) Maximum horizontal reaction = 188 lbs. Maximum horizontal may be increased to 450 lbs by installing 1 - Hilti X-EDNI PAF thru bottom flange into steel.
- 7) Equivalent fasteners may be substituted for these indicated.
- 8) When truss is 2-ply, connection applied to each ply.(Capacities doubled)
- 9) Steel Plate, and it connection to CMU/Concrete wall shall be designed by a qualified designer for design loads.

Revised 6/2001