

CAP OPENING SIDE OF JAMB  
w/TRACK ATTACHED  
w/(1)#10-16 SCREW  
@ 16"o.c. IN EACH LEG.

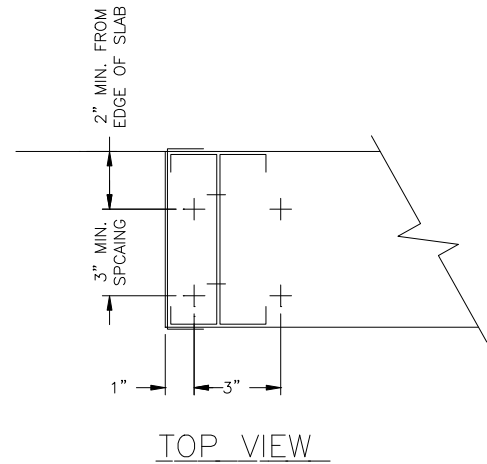

FULL HEIGHT JAMB STUDS.  
MEMBER SIZES AS REQ'D  
PER DESIGN.

ATTACH TRACK END TO SLAB  
USING: (4)0.145"Ø HILTI X-DNI  
P.D.F.'s w/1-1/2" MIN. EMBED.  
LOCATED AS SHOWN ABOVE.  
(FASTENER SIZE & QUANTITY AS  
REQ'D PER DESIGN.)

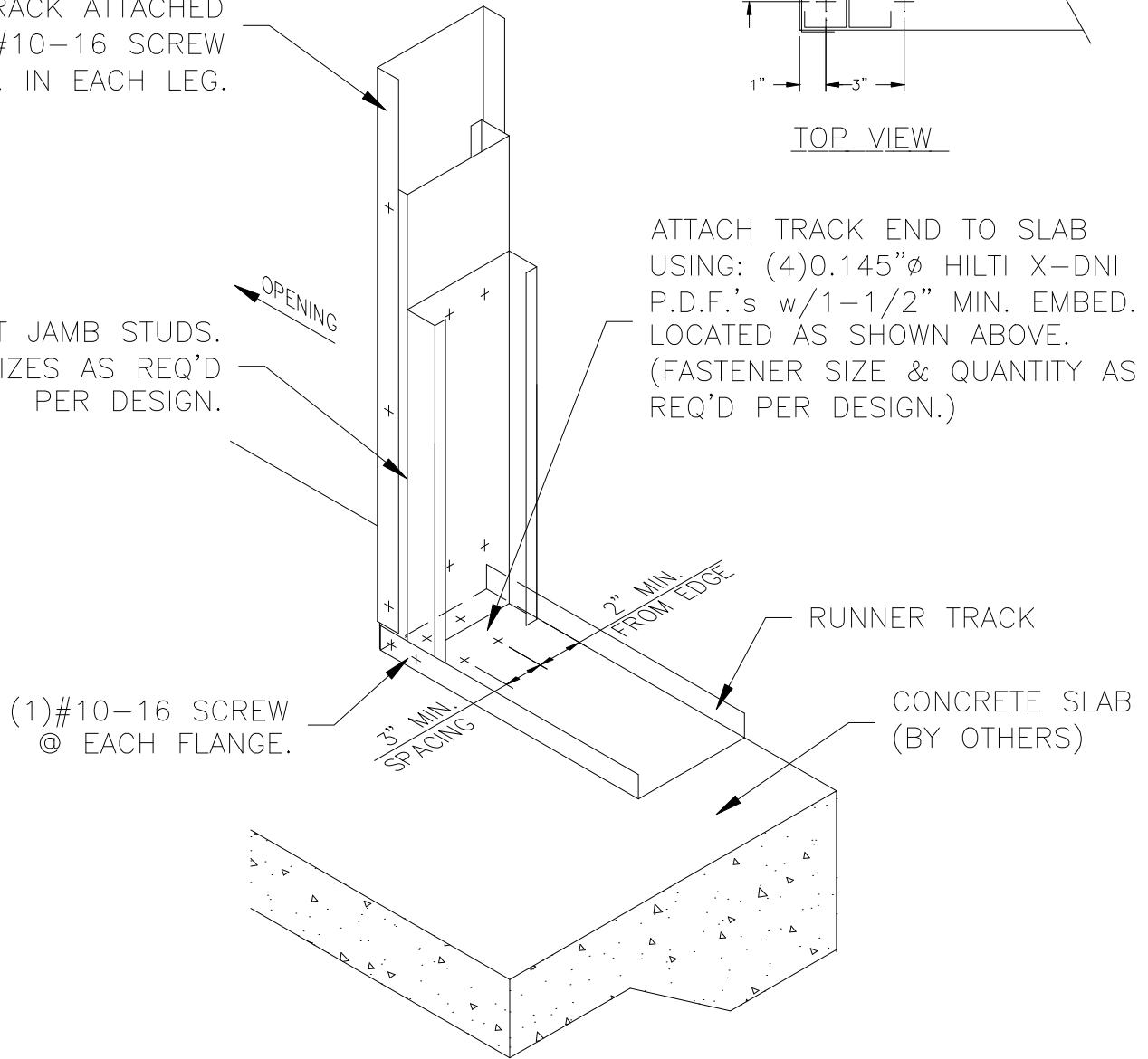

**CLARKWESTERN**  
DESIGN

East Coast - Atlanta, GA  
20 Mansell Court East, Suite 350B  
Roswell, GA 30076

West Coast - San Diego, CA  
2035 Corte Del Nogal, Suite 165  
Carlsbad, CA 92011

Toll Free Phone: 877-832-3206

## DOOR JAMB ANCHORAGE

(2)JAMB ANCHORAGE TO STRUCTURE  
w/(4)P.D.F.'s