

QUICK-CONNECT-SS™: STEEL PIPE POST WITH ANGLED TERMINATION – STAIRS

NOTE: DETAIL IS TYPICAL FOR 1/8", 3/16" AND
1/4" DIAMETER STANDARD CABLERAIL™ ASSEMBLIES.

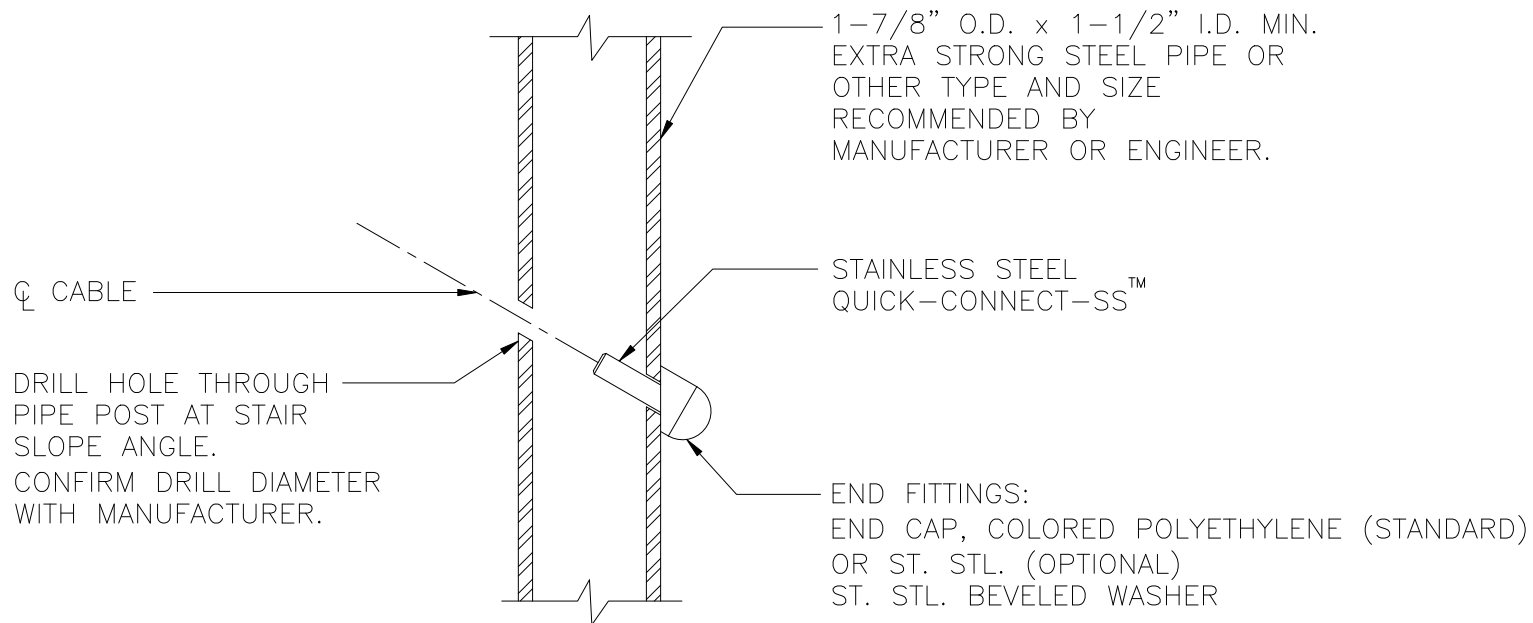

feeneyarchitectural
P R O D U C T S

CableRail™ – Standard Assemblies

2603 Union Street

Oakland, CA 94607-2423

Ph: 800-888-2418 or 510-893-9473

Fx: 510-893-9484, www.cablerail.com