

END COND. TOGGLE DETAIL

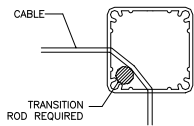

CORNER DETAIL

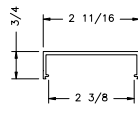

"C" CHANNEL

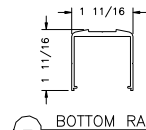

BOTTOM RAIL

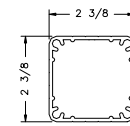

STD. POST

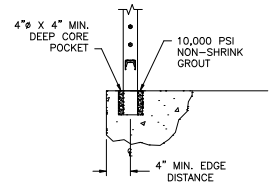

CORE MOUNT

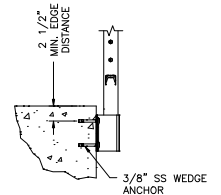

FASCIA MOUNT

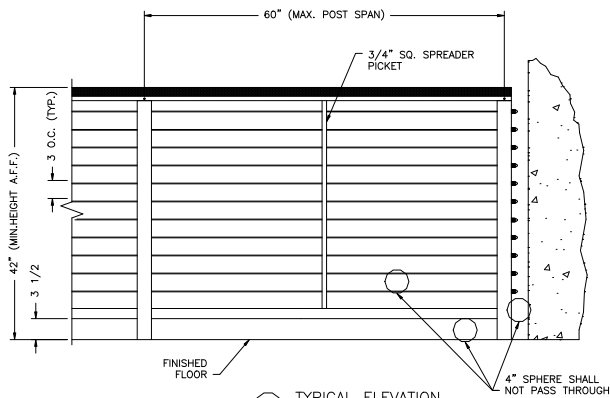

TYPICAL ELEVATION

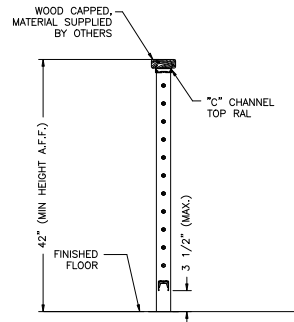

TYPICAL SECTION

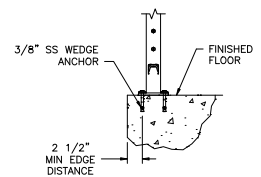

SURFACE MOUNT

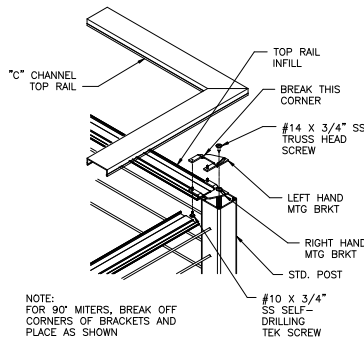

TYP. CORNER CONNECTION

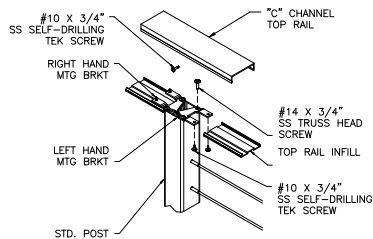

TYP. TOP RAIL CONNECTION

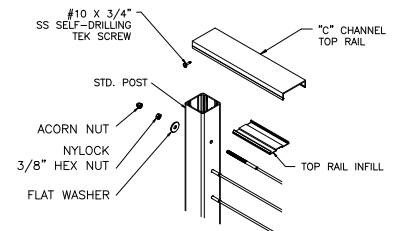

END CONDITION DETAIL

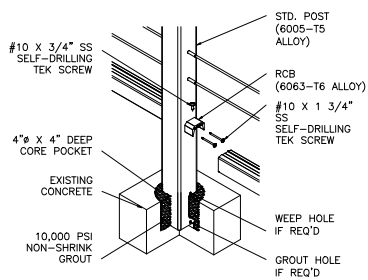

POST ONLY CORE POCKET DETAIL

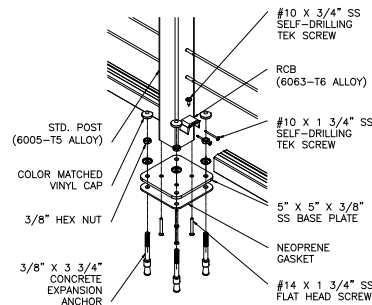

SURFACE MOUNTING DETAIL

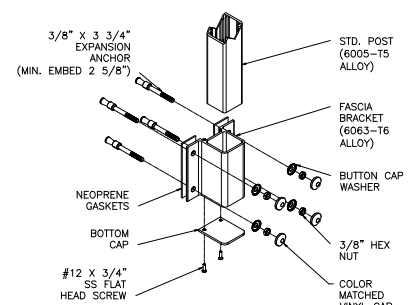

FASCIA MOUNTING DETAIL