

FASCIA MOUNTING DETAILS

SCALE: 1/2"=1'-0"

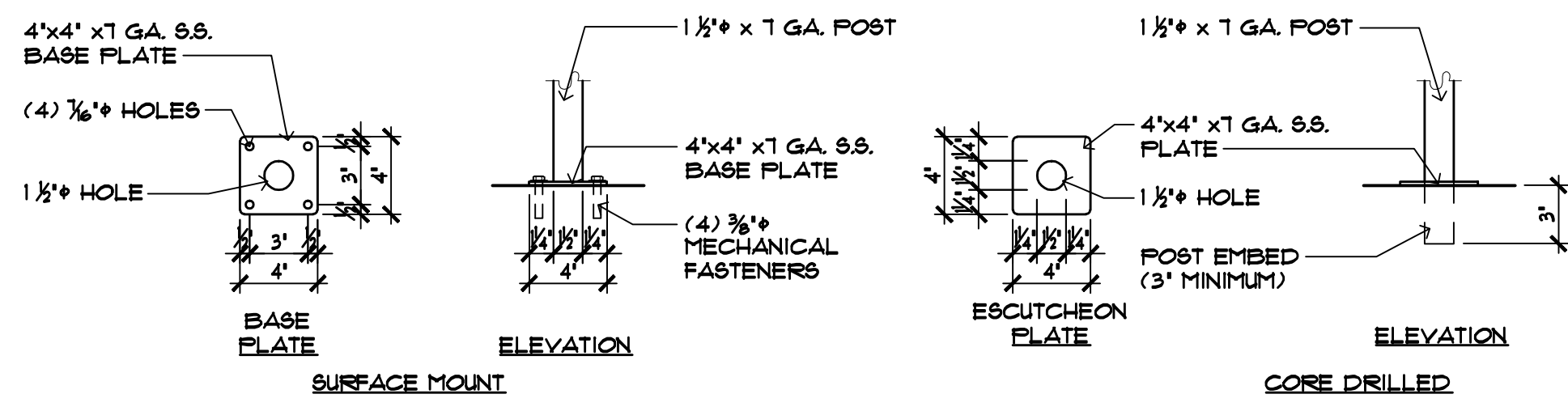

FLOOR MOUNTING DETAILS

SCALE: 1/2"=1'-0"

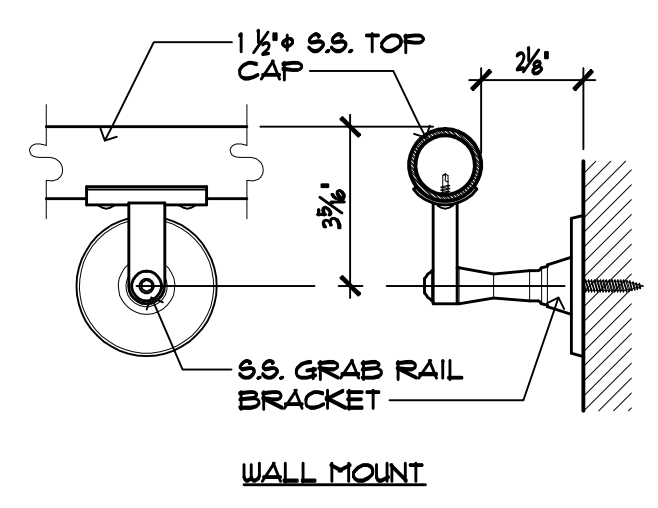

BRACKET DETAILS

SCALE: 3/4"=1'-0"

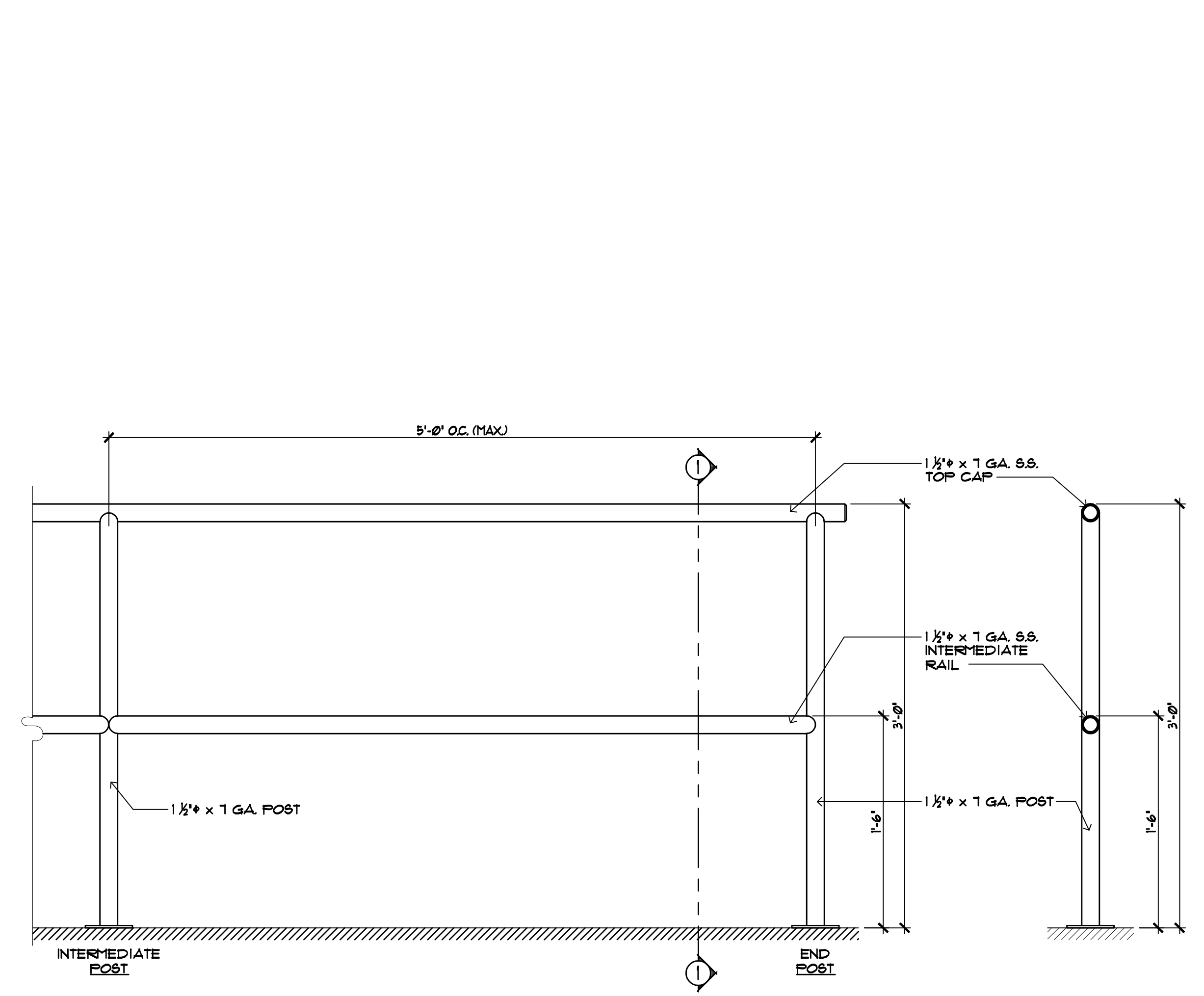

LEVEL RAIL ELEVATION

SCALE: 1/2"=1'-0"

SECTION

SCALE: 1/2"=1'-0"

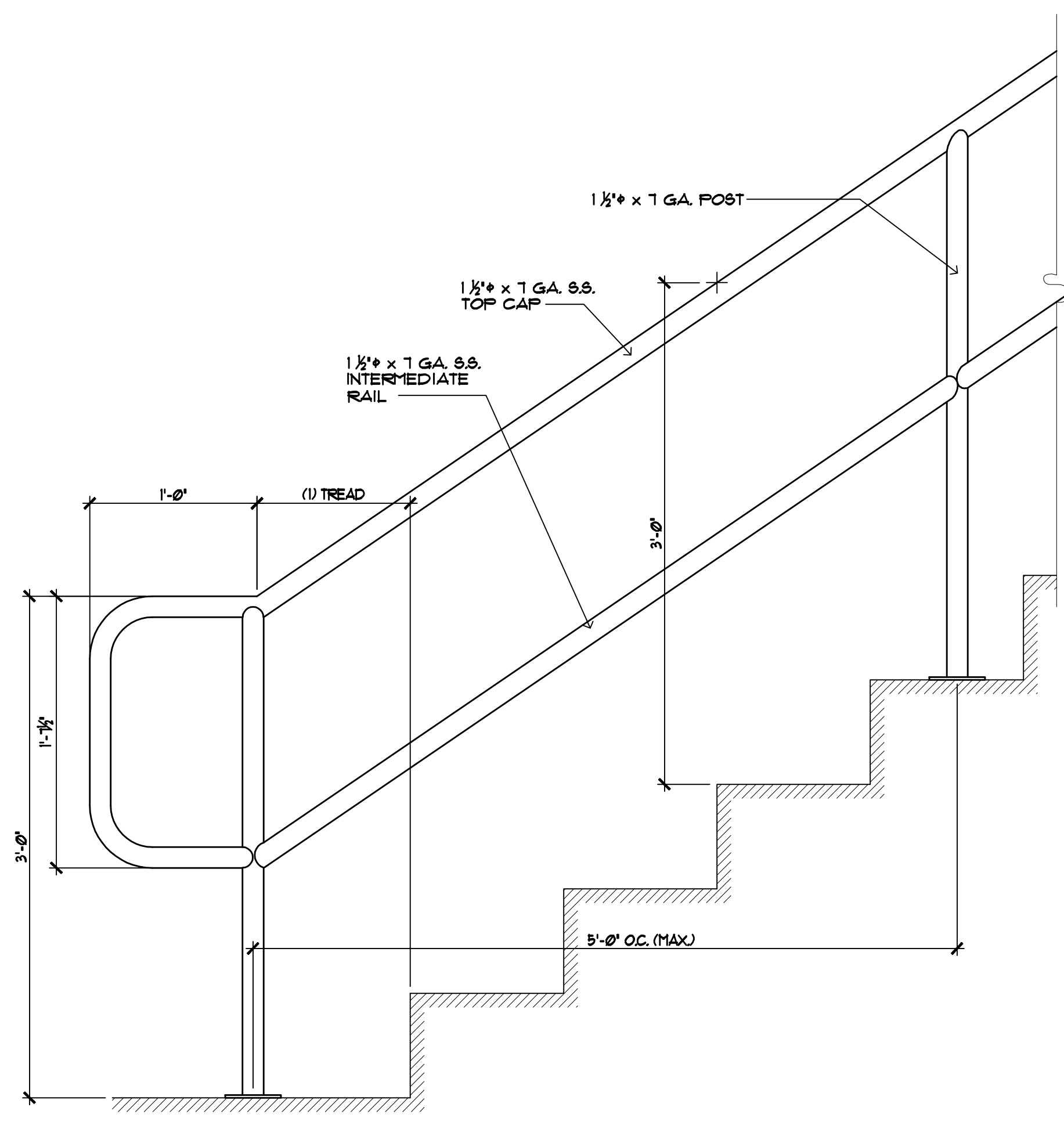

STAIR RAIL ELEVATION

SCALE: 1/2"=1'-0"

NOTES -

- * ALL COMPONENTS TO BE STAINLESS STEEL, #304 ALLOY.
- * ALL EXTERIOR RAILING WITHIN FIVE MILES OF COASTAL WATERS TO BE #316 ALLOY.
- * ALL COMPONENTS TO HAVE #3 BRUSH FINISH UNLESS OTHERWISE REQUESTED.

Product:
DL1-2000 FREESTANDING GRAB RAILING

Notes:
COPY & PASTE MODELSPACE ENTITIES INTO MODELSPACE OF ARCHITECTURAL SET WITH AN INSERTION POINT OF (0,0).
COPY & PASTE PAPERSPACE ENTITIES INTO PAPERSPACE OF ARCHITECTURAL SET AND REACTIVATE ALL VIEWPORTS.

USE COLOR DEPENDANT PLOT STYLES AS FOLLOWS:
 COLOR #240 = .0035" | COLOR #242 = .0059" | COLOR #246 = .0157"
 COLOR #241 = .0209" | COLOR #245 = .0098"

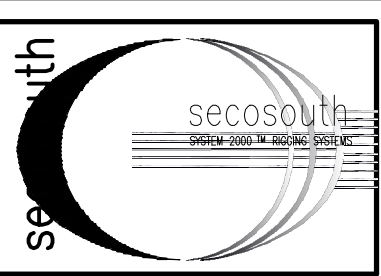

2111 34TH WAY
 LARGO, FL 33771
 PH: 727.536.1924
 FAX: 727.539.6314
 sales@secosouth.com