

5-1/2" (140mm) GABLE END FRAMING

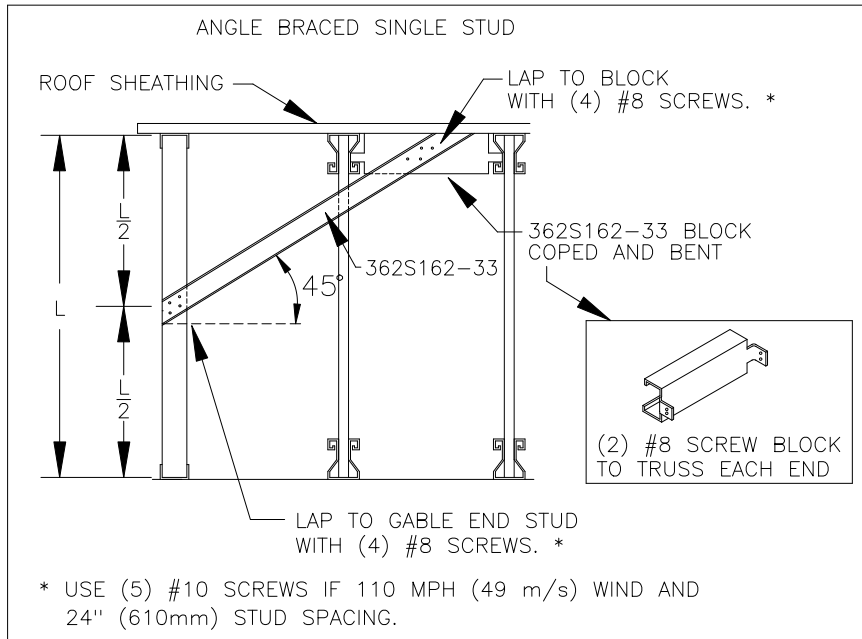

GENERAL NOTES:

1. THE GABLE END TRUSS IS ASSUMED TO BE SUPPORTED VERTICALLY, HORIZONTALLY AND Laterally ALONG ITS ENTIRE LENGTH. THE BUILDING DESIGNER IS RESPONSIBLE FOR THE DESIGN OF THE SUPPORT WALL AND THE CEILING AND ROOF DIAPHRAGM AND THE CONNECTION OF THE GABLE TRUSS TO THESE SUPPORTS.
2. THE DESIGN OF THE GABLE END TRUSS IS BASED ON THE GRAVITY LOADS SHOWN IN THE TITLE BLOCK BELOW ALONG WITH THE FOLLOWING WIND LOAD CRITERIA:
WIND SPEED = 110 MPH (49 m/s) AND 80 MPH (36 m/s)
MEAN HEIGHT = 15' (4572mm) ENCLOSED
ASCE 7-93, I = 1.05, EXPOSURE C
COMPONENTS AND CLADDING LOADING
3. ATTACH THE STUDS TO THE TOP AND BOTTOM TRACK WITH (2) #10 SELF DRILLING AND SELF TAPPING SHEET METAL SCREWS.
4. GABLE STUDS ARE ASSUMED TO BE FULLY BRACED, BY SHEATHING, ALONG THEIR ENTIRE LENGTH FOR IN-TRUSS-PLANE BUCKLING. SHEATHING AND ITS CONNECTION TO THE GABLE TRUSS IS TO BE DESIGNED BY THE BUILDING DESIGNER.
5. ALL MATERIAL IS UNIMAST AS SHOWN OR EQUAL.
6. INTENDED FOR USE WITH ALPINE TrusSteel TRUSSES ONLY.
7. METRIC UNITS: TOP CHORD LIVE LOAD IS 1.44 kN/m², TOP CHORD DEAD LOAD IS 0.34 kN/m², BOTTOM CHORD DEAD LOAD IS 0.34 kN/m² AND TOTAL LOAD IS 2.11 kN/m².

362S162-33 STUD MAXIMUM LENGTH					
	STUD SPACING	WIND SPEED MPH (m/s)	DEFLECTION CRITERIA		
			L/180	L/240	L/360
STRONG AXIS LATERALLY UNBRACED SINGLE STUD	24" (610mm)	110 (49)	8'9" (2667mm)	8'9" (2667mm)	8'9" (2667mm)
		80 (36)	12'0" (3658mm)	12'0" (3658mm)	11'1" (3378mm)
	16" (406mm)	110 (49)	10'9" (3277mm)	10'9" (3277mm)	10'3" (3124mm)
		80 (36)	14'9" (4496mm)	14'6" (4420mm)	12'8" (3861mm)
ANGLE BRACED SINGLE STUD	24" (610mm)	110 (49)	13'10" (4216mm)	13'10" (4216mm)	13'10" (4216mm)
		80 (36)	17'7" (5359mm)	17'7" (5359mm)	17'7" (5359mm)
	16" (406mm)	110 (49)	16'1" (4902mm)	16'1" (4902mm)	16'1" (4902mm)
		80 (36)	20'9" (6325mm)	20'9" (6325mm)	20'9" (6325mm)
STRONG AXIS LATERALLY UNBRACED DOUBLED STUDS	24" (610mm)	110 (49)	12'5" (3785mm)	12'5" (3785mm)	11'3" (3429mm)
		80 (36)	17'0" (5182mm)	16'0" (4877mm)	13'11" (4242mm)
	16" (406mm)	110 (49)	15'2" (4623mm)	14'9" (4496mm)	12'11" (3937mm)
		80 (36)	20'2" (6147mm)	18'3" (5563mm)	16'0" (4877mm)

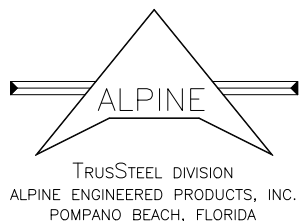
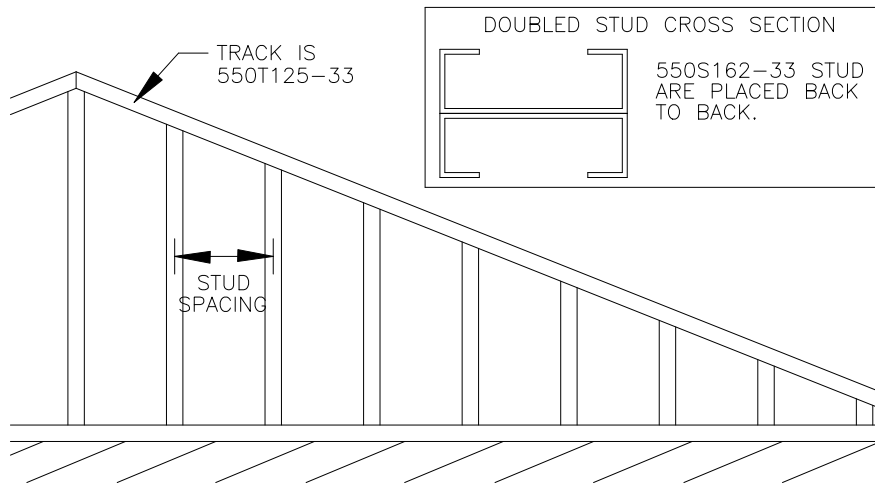

****WARNING**** TRUSSES REQUIRE EXTREME CARE IN FABRICATING, HANDLING, SHIPPING INSTALLING AND BRACING. UNLESS OTHERWISE INDICATED, TOP CHORD SHALL HAVE PROPERLY ATTACHED STRUCTURAL PANELS AND BOTTOM CHORD SHALL HAVE A PROPERLY ATTACHED RIGID CEILING.

****IMPORTANT**** FURNISH A COPY OF THIS DESIGN TO THE INSTALLATION CONTRACTOR. BRACING DEPICTED ON THIS DESIGN IS ONLY FOR LATERAL SUPPORT OF TRUSS MEMBERS TO REDUCE BUCKLING LENGTHS. ALL DESIGN, ATTACHMENT AND INSTALLATION OF TEMPORARY AND PERMANENT BRACING, TO RESIST LATERAL FORCES AND HOLD TRUSSES PLUMB, SHALL BE THE RESPONSIBILITY OF OTHERS. ALPINE ENGINEERED PRODUCTS, INC. SHALL NOT BE RESPONSIBLE FOR ANY DEVIATION FROM THIS DESIGN OR HANDLING, SHIPPING, INSTALLING, AND BRACING OF TRUSSES. AN ENGINEER'S SEAL ON THIS DRAWING APPLIES ONLY TO DESIGN OF THE TRUSS DEPICTED HERE AND SHALL NOT BE RELIED UPON IN OTHER WAY.

TC LL	30.0 PSF
TC DL	7.0 PSF
BC DL	7.0 PSF
BC LL	0.0 PSF
TOT. LD.	44.0 PSF

SEE NOTE 7 FOR
METRIC UNITS

TrusSteel DETAIL
DATE 12/21/01
DRWG TS014
-ENG