

TSC2.75 PLY TO PLY CONNECTION WHEN HANGERS ARE USED TO SUPPORT TRUSSES

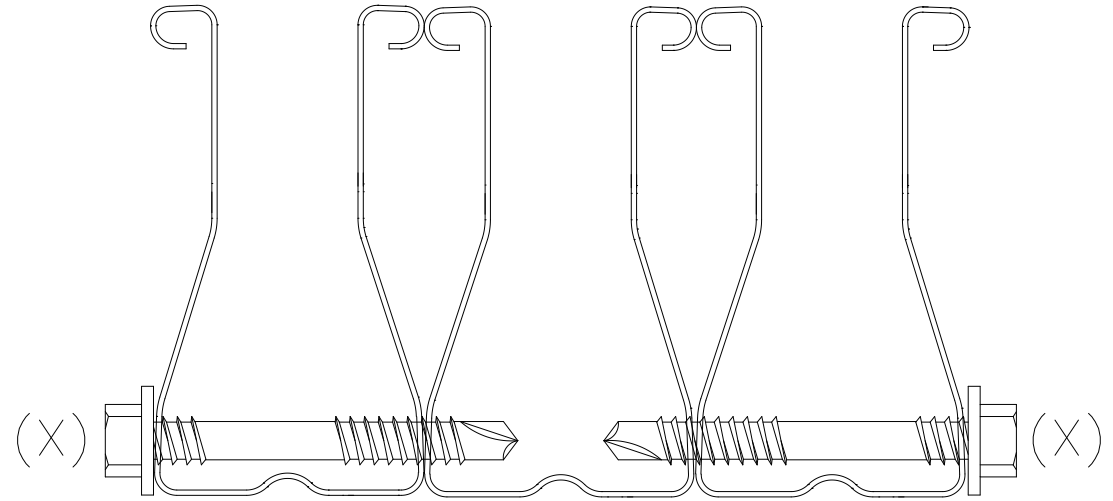
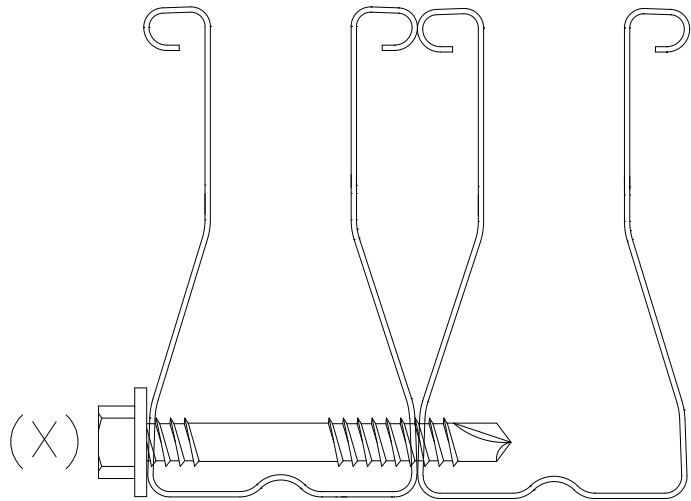

TSC2.75 2-PLY CONNECTION

TSC2.75 3-PLY CONNECTION

GENERAL NOTES:

1. SCREW CONNECTION SHOWN TO BE APPLIED WITHIN 12" (305mm) OF THE SUPPORTED TRUSS.
2. SCREW(S) NOT TO BE LOCATED AT A PANEL POINT.
3. SCREWS(X) = #14AMDB2.125 SELF-DRILLING SCREW.
4. IF MORE THAN ONE SCREW IS REQUIRED, SPACING AND END DISTANCE OF SCREWS = 0.75" (19mm).

NUMBER OF SCREWS TO BE APPLIED AT EACH CONCENTRATED LOAD LOCATION

REACTION FROM SUPPORTED TRUSS lbs. (kN)	28TSC (22ga)	33TSC (20ga)	43TSC (18ga)
	(X)=# OF SCREWS	(X)=# OF SCREWS	(X)=# OF SCREWS
200 (0.89)	1	1	1
400 (1.78)	2	1	1
600 (2.67)	2	2	1
800 (3.56)	3	2	1
1000 (4.45)	3	2	2
1200 (5.34)	4	3	2
1380 (6.14)	4	3	2

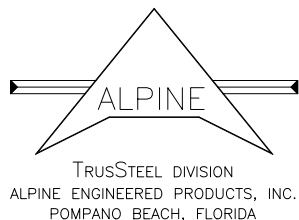

****WARNING**** TRUSSES REQUIRE EXTREME CARE IN FABRICATING, HANDLING, SHIPPING INSTALLING AND BRACING. UNLESS OTHERWISE INDICATED, TOP CHORD SHALL HAVE PROPERLY ATTACHED STRUCTURAL PANELS AND BOTTOM CHORD SHALL HAVE A PROPERLY ATTACHED RIGID CEILING.

****IMPORTANT**** FURNISH A COPY OF THIS DESIGN TO THE INSTALLATION CONTRACTOR. BRACING DEPICTED ON THIS DESIGN IS ONLY FOR LATERAL SUPPORT OF TRUSS MEMBERS TO REDUCE BUCKLING LENGTHS. ALL DESIGN, ATTACHMENT AND INSTALLATION OF TEMPORARY AND PERMANENT BRACING, TO RESIST LATERAL FORCES AND HOLD TRUSSES PLUMB, SHALL BE THE RESPONSIBILITY OF OTHERS. ALPINE ENGINEERED PRODUCTS, INC. SHALL NOT BE RESPONSIBLE FOR ANY DEVIATION FROM THIS DESIGN OR HANDLING, SHIPPING, INSTALLING, AND BRACING OF TRUSSES. AN ENGINEER'S SEAL ON THIS DRAWING APPLIES ONLY TO DESIGN OF THE TRUSS DEPICTED HERE AND SHALL NOT BE RELIED UPON IN OTHER WAY.

TrusSTEEL DETAIL
 DATE 12/21/01
 DRWG TS023
 -ENG